

English

- [Oilon.com \(/main/\)](http://www.oilon.com/)
(<http://www.oilon.com/scancool/EN/>)
- [Industries \(/industry/\)](#)
- [Oilon Home \(/oilon-home/en/\)](#)
- [Oilon Scancool \(/scancool/EN/\)](#)
- [Customer service \(/customer-service/\)](#)
- [Extranet \(http://login.oilon.com/?_r=http%3a%2f%2foilon.com%2fextranet%2fmain\)](#)
- [OilonChooser \(http://oilon.com/oilonchooser/index.php?page=terms&action#\)](#)
- [Webshop \(http://webshop.oilon.com/index.php?main_page=index&language=en\)](#)

Oilon develops a cooling and heating concept for Resort Hotels for tropical and sub-tropical climate zones

2016-10-12

Oilon Scancool has come up with a novel concept for enhancing energy balance in the hotel sector by replacing the conventional chillers used for central air conditioning and acclimatization using a heat pump. The concept eliminates completely need for combustion in heating water for bath, kitchen, laundry and swimming pool. On top of providing significant economy for the hotels, eliminating the use of fossil fuels contributes on reducing establishment's direct carbon footprint, providing a sustainable option for ecologically aware travelers.



The heat pump concept uses a traditional refrigeration circuit taking advantage of both, condensing and evaporating of the refrigerant in the same cycle, making the concept one of the most energy-efficient technologies currently available. By means of an electricity driven compressor the enthalpy of the refrigerant inside the pump is increased, which, when condensed and then evaporated against external water circuit, changes constantly its physical form and by doing so, liberates significant amount of thermal energy for use of the process. The secret of the energy-efficiency compared to a conventional refrigeration circuit is the fact that heat pump application uses also the condensing heat as benefit, when normally the heat created by the i.e. the chillers in hotels is dissipated into the atmosphere.

In most of the big hotel complexes and holiday resorts located between the tropics of Cancer and Capricorn, the energy consumption is heavily increased due to demand for air conditioning and cooling in this hot tropical / sub-tropical zone. In

addition, there is a need for hot bathing water, laundry and kitchen use and in several occasions the hotel also takes care of its own laundry, usually by having gas or diesel fired boilers to cover all these hot water needs.

The selection point of Oilon ChillHeat heat pump is to cover completely the cooling needs of the resort. In majority of this kind of resorts and hotels, the central air conditioning runs constantly with some modulation throughout the 24 hour cycle, but the hot water need has specific peak hours, during the mornings and in the evenings, being almost inexistent during the night time. The amount of cooling TRs needed in these hotels is at least three to four times bigger than the kCals needed for heating. This means that by using the chilled water circuit as a heat source, a heat pump is constantly able to provide hot water to the hotel in any temperature and quantity required.

In order to make the system run on optimized performance coefficient and to make it respond redundantly to the heating and cooling needs at any times, a special attention was given to use of liquid air cooler, allowing temperature control of the cooling circuit heat removal and intelligently operating in reverse mode in a role of a heat source, whenever the chilled water circuit is not in use, like normally during the nights when temperature falls below 25°C.



Hotel Resort (Tropical / Subtropical)

Heat redundant system to cover all cooling and heating needs of the hotel using heat pump.

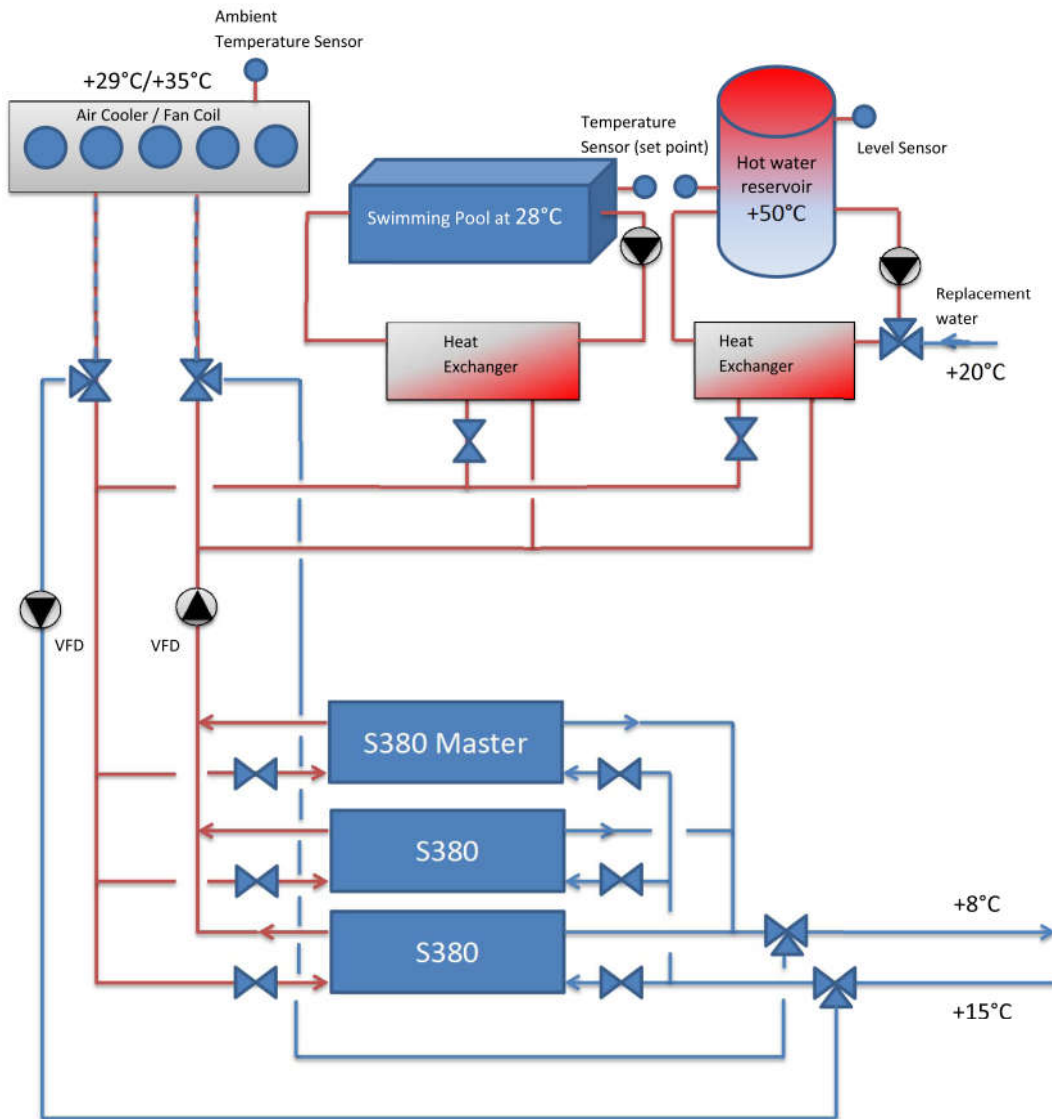

Master Heat pump controls the outgoing cold side temperature at setpoint (+8C). At the same time it keeps the outgoing warm side temperature at setpoint, depending on desired heat sink by regulating the warm side flow. In case the chiller circuit cannot be used as a heat source (cold days), the air cooler function is inverted to operate as a secondary heat source when heating is needed.

(http://www.oilon.com/uploadedImages/Scancool/News/Scancool_News/Resort%20concept%20OBR%20061016%20r1.jpg)

Click the picture to view larger version

The system has three running modes:

1. Operation as a chiller; swimming pool water temperature and hot water reservoir temperature and level are good, all the heat generated by the refrigeration circuit is dissipated through the liquid air cooler and water flow temperature is kept low by means of frequency converter controlled circulation pump in order to preserve the performance coefficient (COP).
2. Heating of water in the reservoir and/or swimming pool; two-way adjustable flow balancing valves installed before the heat exchangers and the liquid air cooler adjust and balance the flow for heating needs in each of the heat sinks. The automatic set point for this is either the temperature sensors installed in the pool and reservoir tank to recirculate the water or the level sensor in the reservoir, in which case the fresh replacement water is heated up entering the reservoir. Each of these heat sinks is able to operate individually, programmed into the heat pump automation, and the excess heat, not needed for water heating, is again dissipated through the liquid air cooler. In parallel heat pump constantly maintains the chilled water temperature at the set point (at 8°C in the above example).

3. Heating only mode; in this running mode there is no need for air conditioning or cooling in the establishment and chilled water circuit cannot be used as a heat source. In the tropical / sub-tropical zone this happens during a couple of months during the year in the night time, having temperatures below 20°C. In this running mode, the function of the liquid air cooler is inverted and instead of dissipating heat into the atmosphere like in the other running modes, Oilon ChillHeat concept uses the outside ambient air as a heat source to run the same heat pumps now only for heating purposes and thus guarantees hot shower for the visitor as of early in the morning, when the peak hot water consumption starts. Once the sun rises up again and provokes a need for air conditioning, the system automatically inverts the liquid air cooler function as programmed into the heat pump logic.

The system described in this context is modular and can be installed for any requested cooling capacity, further, there is no limitations in the number of different heat sinks, as all the lines and flows can be adjusted and pre-set into the heat pump automation.

In addition to not having to spend a dime to buy gas or diesel for heating purposes, in the ChillHeat concept's residual heat circuit, the water temperature going to the fan coil can be automatically adjusted according to the outside ambient temperature in order to maintain the running window on optimal COP value for the prevailing conditions. This makes the concept more economical than conventional chillers, even when running on same HFC refrigerant.

By using frequency converter driven fans in the liquid cooler, the fan rotation speeds can be kept on low level to guarantee silent operation, especially during the night time.

The closed cold water solutions circuits guarantee trouble-free operation and savings preventing dirt from getting into the circuit and water evaporation into the atmosphere, as in the traditional chiller-cooling tower –concepts.

Please contact us for a study at your resort:

Pertti Latikka,

Oilon South America – southamerica@oilon.com (mailto:southamerica@oilon.com) - +55 15 3228 4000

0

Latest news

Our heat pumps have won awards for energy efficiency in Uruguay (</scancool/news/Our-heat-pumps-have-won-awards-for-energy-efficiency-in-Uruguay/>)2016-12-07

Oilon develops a cooling and heating concept for Resort Hotels for tropical and sub-tropical climate zones (</scancool/news/Oilon-develops-a-cooling-and-heating-concept-for-Resort-Hotels-for-tropical-and-sub-tropical-climate-zones/>)2016-10-12

Wastewater plants start cooperation in energy savings and heat recovery (</scancool/news/wastewater-plants-start-cooperation-in-energy-savings-and-heat-recovery/>)2016-09-01

Industrial refrigeration and heat pump knowledge required in dairy removal and renewal (</scancool/news/industrial-refrigeration-and-heat-pump-knowledge-required-in-dairy-removal-and-renewal.aspx>)2016-05-23

Industrial heat pump and MobileDrive gained visibility in Nordbygg (</scancool/news/industrial-heat-pump-and-MobileDrive-gained-visibility-in-Nordbygg/>)2016-04-15

Mobile user interface of industrial heat pump for your smart phone or tablet (</scancool/news/mobile-user-interface-of-industrial-heat-pump-for-your-smart-phone-or-tablet/>)2016-04-05

Another set of industrial heat pumps for cooling and heating in MAX IV-laboratory (</scancool/news/another-set-of-industrial-heat-pumps-for-cooling-and-heating-in-MAX-IV-laboratory/>)2016-03-15

Energy efficiency a central topic in the industrial refrigeration event (</scancool/news/energy-efficiency-a-central-topic-in-the-industrial-refrigeration-event/>)2016-03-04

We exhibit in Nordbygg, Stockholm 5-8 April 2016 (</scancool/news/we-exhibit-in-nordbygg/>)2016-02-24

Meet us in Energy & Buildings event 2016 (</scancool/news/energy-and-buildings-event-2016/EN/>)2016-02-19

Refrigeration is an essential part of the production process in a feed plant (</scancool/news/refrigeration-is-an-essential-part-of-the-production-process-in-a-feed-plant/EN/>)2016-02-17

Industrial refrigeration event in Vantaa, Finland (</scancool/news/industrial-refrigeration-event-in-Vantaa-Finland/>)2016-02-11

Central district cooling introduced in Tampere, Finland (</scancool/uutiset/central-district-cooling-introduced-in-Tampere-Finland/EN/>)2015-08-27

Airport building in Montevideo, the capital of Uruguay, to be cooled and heated using Finnish heat pumps from Oilon Scancool Oy (</scancool/uutiset/airport-building-in-montevideo-the-capital-of-uruguay-to-be-cooled-and-heated-using-finnish-heat-pumps-from-oilon-scancool-oy/EN/>)2015-08-27

Oilon Scancool to deliver combined cooling/heating pump system for a particle accelerator laboratory

(/scancool/uutiset/MAX-lab/EN/)2014-05-21

Oilon Scancool will participate at the Nordbygg fair at Stockholm, Sweden April 1-4 (/scancool/uutiset/Nordbygg/EN/)2014-03-05

New Oilon ChillHeat -series (/scancool/news/oilon_chillheat_series/)2013-09-09

Jeppo Biogas Ab places an order for heat pumps (/scancool/news/jeppo-biogas/)2013-07-01

Oilon Scancool to provide unique Hybrid Renewable Energy System for Helsinki Energy (/scancool/news/Helsinki-Energy/)2013-06-24

Waste Heat System for Sipoo Dairy, Finland, utilizing Heat Pump Technology (/scancool/news/sipoo/)2013-04-18

(<http://www.youtube.com/user/OilonTheWarmWay>)

(<https://www.facebook.com/OilonHome>) (<https://www.facebook.com/OilonUSInc>)

(<http://www.linkedin.com/company/oilon>) (<http://www.slideshare.net/Oilon>)

(<http://twitter.com/OilonFI>)

Customer Service

+358 (0)207 281 868

(/customer-service/)

Phone: **+358 3 85 761** E-mail: **info@oilon.com** Address: **Metsä-Pietilänkatu 1,
P.O. Box 5, FI-15801 Lahti, Finland**

[Oilon.com \(/main/\)](/main/) [Industries \(/industry/\)](/industry/) [Oilon Home \(/oilon-home/en/\)](/oilon-home/en/) [Oilon Scancool \(/scancool/EN/\)](/scancool/EN/)

[Customer service \(/customer-service/\)](/customer-service/)

Extranet (http://login.oilon.com/?_r=http%3a%2f%2foilon.com%2fextranet%2fmain)

OilonChooser (<http://oilon.com/oilonchooser/index.php?page=terms&action#>)

Webshop (http://webshop.oilon.com/index.php?main_page=index&language=en)

